



This oven was designed with bagels in mind and therefore designed with the required deck entrance height and interior height.

The oven itself has the same technical characteristics as the Baby Rembrandt and so has the same advantages.

Manufactured with stainless steel lids for better overall bake back to front. High quality insulation and low consumption guaranteed due to unique closed circuit steam tube system which holds heat captured for a long period of time.

Baking surface made of the finest refractory stone to give that hearth bake taste, crunchy outer layer and soft interior for the most tasty bagels you have ever baked.

Available in three versions, 3 deck/2 stones wide, 3 deck/3 stones wide and 3 decks/4 stones wide. Our models are manufactured so that it still will fit through a standard door.



BAGEL ACCESSORIES



BAGEL TROUGH

- 3 Drains
- Seed keeper to not plug drain
- Lower storage shelf

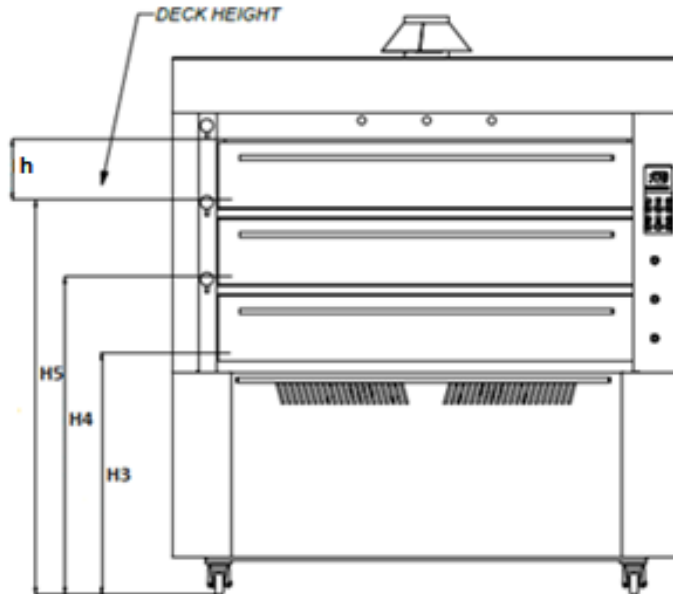
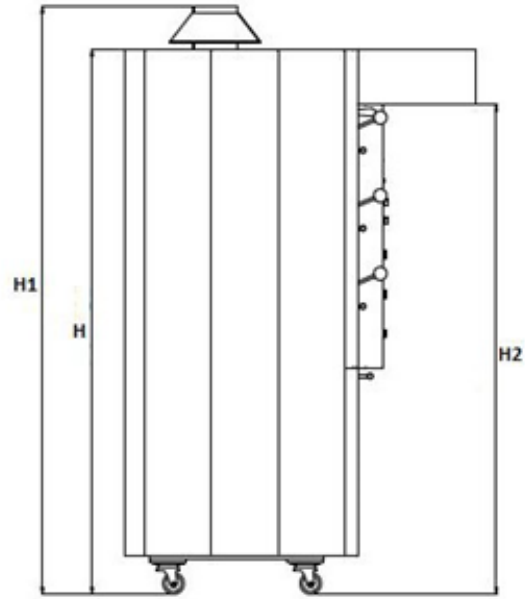
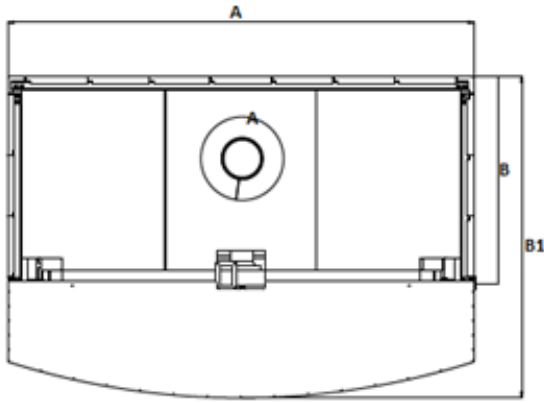

Description		PM-BTO 20	PM-BTO 30	PM-BTO 40
Control Unit		Electro mechanic / Touch screen		
Type		Gas	Gas	Gas
Number of decks & entrances		3 decks / 2 entrances	3 decks / 3 entrances	3 decks / 4 entrances
Baking area		20 ft2	30 ft2	40 ft2
Width	A	56.89"	76.57"	96.26"
Lenght	B	34.64"	34.64"	34.64"
Length (incl. hood)	B1	55.51"	55.51"	55.51"
Height	H	80.31"	80.31"	80.31"
Height (incl. cap)	H1	86.61"	86.61"	86.61"
Height (till hood)	H2	73.22"	73.22"	73.22"
	H3	35.43"	35.43"	35.43"
	H4	47.63"	47.63"	47.63"
Deck entrance height	H5	59.25"	59.25"	59.25"
	a	39.37"	59.05"	78.74"
Inner dimensions	b	27.55"	27.55"	27.55"
	h	9.05"	9.05"	9.05"
	220VAC/60Hz + N + PE			
Voltage		220VAC/60Hz + N + PE		
Electrical power		4 amps	4 amps	5 amps
Heating capacity		111 112.96 Btu	111 112.96 Btu	136 907.05 Btu
Max. temperature		572°F	572°F	572°F
Weight		2866 lb	3306 lb	4078 lb



PROMAC Bakery Equipment
 170 Wilbur Place, Suite 300, Bohemia NY 11716
 Direct Phone & Service: (516) 286-3609
 Website: www.promacbakeryequipment.com
 Mail: info@promacbakeryequipment.com