

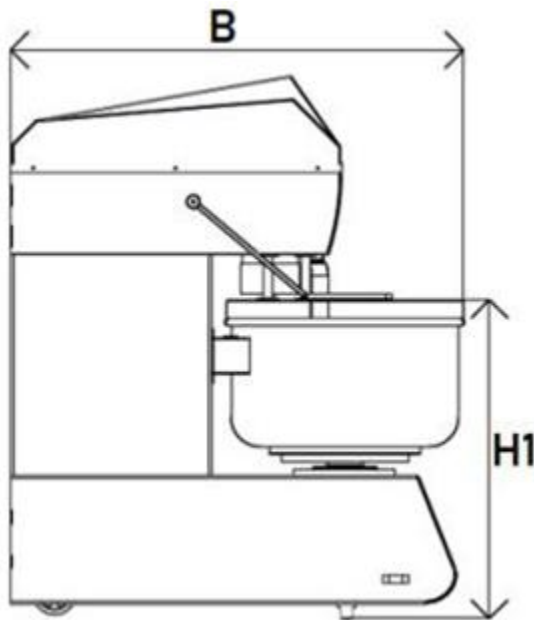

- Spiral arm with dual speed mixing
- Bowl with dual speed mixing
- Mixing capacity as low as 20% of its max capacity
- Stainless steel bowl, spiral arm, central bar and bowl guard
- Programmable timers which can be set for 1st and 2nd speed
- Poly-V pulley and belt system for more torque and clutch
- Works silently
- Heavy duty rubber feet for secure mixing
- Automatic or manual working options
- Heavy duty casters
- Electro static paint
- Bi-directional bowl

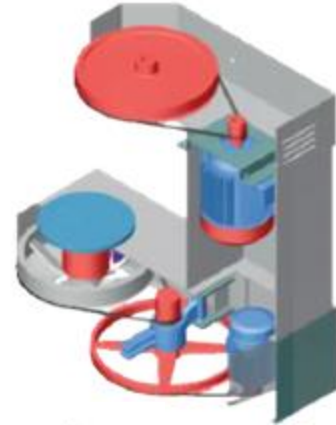

Description	PM-SPM 40/2	PM-PSM 60/2	PM-PSM 80/2	PM-PSM 100/2
Control Unit	Electro mechanic / Print Card Board			
Bowl capacity	15 gal	25 gal	34 gal	38 gal
Flour capacity	11 to 55 lb	15 to 77 lb	22 to 110 lb	27 to 137 lb
Dough capacity	88 lb	132 lb	176 lb	220 lb
Bowl diameter	20.86"	23.62"	27.55"	27.55"
Length	A 22.04"	24.80"	28.74"	28.74"
Width	B 40.55"	44.48"	48.03"	48.03"
Height	H 49.60"	51.57"	56.29"	56.29"
Bowl height	H1 27.16"	29.52"	33.07"	34.64"
Voltage	220VAC/60Hz + N + PE			
Electrical power	3-7 amps	5-9 amps	9-15 amps	9-15 amps
Spiral rotation speed	105/210 rpm	105/210 rpm	105/210 rpm	105/210 rpm
Spiral thickness	9.84"	11.81"	13.77"	13.77"
Bowl rotation speed	10/20 rpm	10/20 rpm	10/20 rpm	10/20 rpm
Bowl left/right rotation	YES	YES	YES	YES
Weight	617 lb	683 lb	1157 lb	1168 lb

Description	PM-SPM 130/2	PM-PSM 160/2	PM-PSM 200/2
Control Unit	Electro mechanic / Print Card Board		
Bowl capacity	54 gal	68 gal	76 gal
Flour capacity	35 to 176 lb	44 to 220 lb	55 to 275 lb
Dough capacity	286 lb	352 lb	440 lb
Bowl diameter	31.49"	35.43"	35.43"
Length	A 32.67"	36.61"	75.98"
Width	B 54.33"	61.41"	61.41"
Height	H 59.05"	61.02"	61.02"
Bowl height	H1 35.04"	35.43"	37"
Voltage	220VAC/60Hz + N + PE		
Electrical power	11-16 amps	14-20 amps	14-20 amps
Spiral rotation speed	105/210 rpm	105/210 rpm	105/210 rpm
Spiral thickness	15.74"	17.71"	17.71"
Bowl rotation speed	10/20 rpm	10/20 rpm	10/20 rpm
Bowl left/right rotation	YES	YES	YES
Weight	1300 lb	1719 lb	1752 lb

PROMAC Bakery Equipment
 170 Wilbur Place, Suite 300, Bohemia NY 11716
 Direct Phone & Service: (516) 286-3609
 Website: www.promacbakeryequipment.com
 Mail: info@promacbakeryequipment.com