

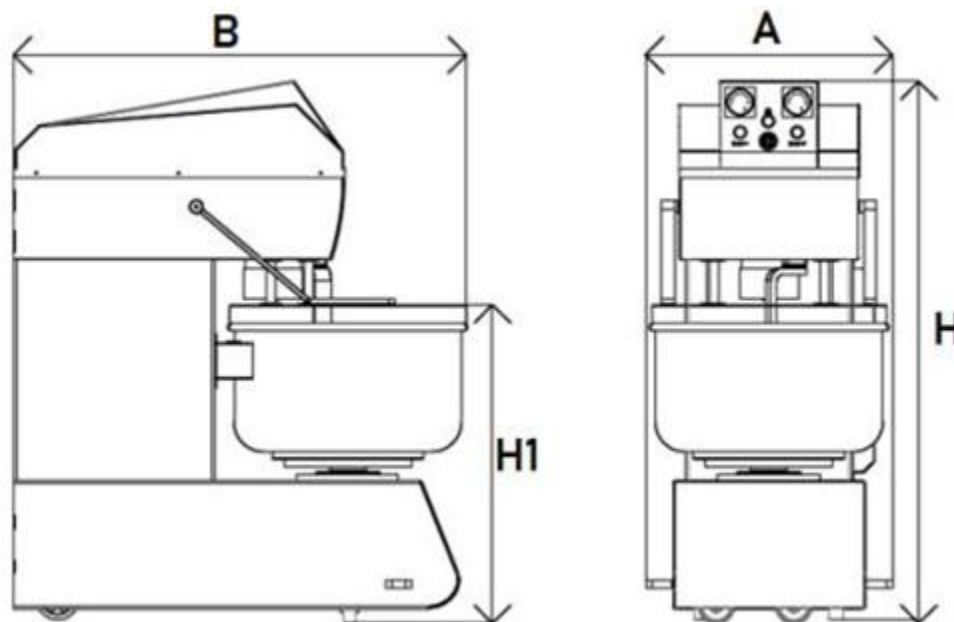

- BOSCH / REXROTH hydraulic system and cylinders
- Removable bowl rotation system equipped with massive heavy duty gear
- Spiral arm with dual speed mixing
- Mixing capacity as low as 20% of its max. capacity
- Stainless steel bowl, spiral and central arm
- Stainless steel bowl cover
- Programmable timers which can be set for first and second speed separately
- Poly-V pulley and belt system for more torque and clutch
- Works silently
- Heavy duty rubber feet for secure mixing
- Automatic or manual use
- Electro static paint
- Extra pulley belt system for harder dough

PROMAC Bakery Equipment
170 Wilbur Place, Suite 300, Bohemia NY 11716
Direct Phone & Service: (516) 286-3609
Website: www.promacbakeryequipment.com
Mail: info@promacbakeryequipment.com



Description		PM-SPM 80 RB	PM-PSM 100 RB	PM-PSM 130 RB
Control Unit		Electro mechanic / Print Card Board		
Bowl capacity		34 gal	38 gal	54 gal
Flour capacity		25 to 110 lb	28 to 137 lb	36 to 176 lb
Dough capacity		176 lb	220 lb	286 lb
Bowl diameter		27.55"	27.55"	31.49"
Width	A	28.74"	28.74"	32.67"
Length	B	48.03"	48.03"	54.33"
Height	H	56.29"	56.29"	59.05"
Bowl height	H1	33.07"	34.64"	35.04"
Voltage		220VAC/60Hz + N + PE		
Electrical power		9-15 amps	9-15 amps	11-16 amps
Spiral rotation speed		105/210 rpm	105/210 rpm	105/210 rpm
Spiral thickness		13.77"	13.77"	15.74"
Bowl rotation speed		10/20 rpm	10/20 rpm	10/20 rpm
Bowl left/right rotation		YES	YES	YES
Weight		2292 lb	2314 lb	2733 lb

PROMAC Bakery Equipment
 170 Wilbur Place, Suite 300, Bohemia NY 11716
 Direct Phone & Service: (516) 286-3609
 Website: www.promacbakeryequipment.com
 Mail: info@promacbakeryequipment.com

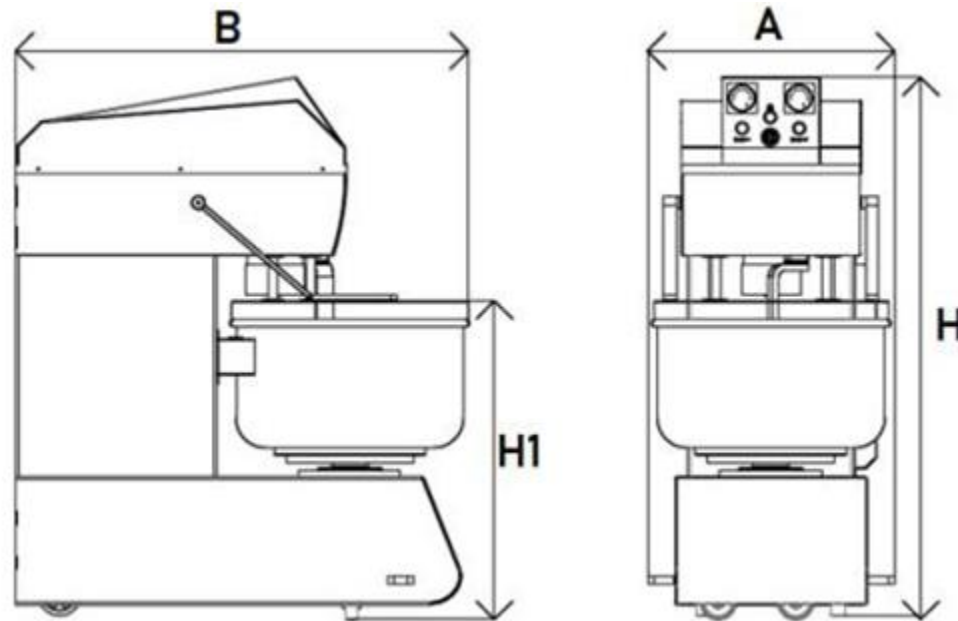

Description		PM-SPM 160 RB	PM-PSM 200 RB	PM-PSM 250 RB
Control Unit		Electro mechanic / Print Card Board		
Bowl capacity		69 gal	77 gal	92 gal
Flour capacity		44 to 220 lb	55 to 275 lb	66 to 330 lb
Dough capacity		352 lb	440 lb	551 lb
Bowl diameter		35.43"	35.43"	39.37"
Width	A	46.06"	46.06"	48.03"
Length	B	59.84"	59.84"	59.84"
Height	H	62.20"	62.20"	63.77"
Bowl height	H1	35.43"	37"	37.40"
Voltage		220VAC/60Hz + N + PE		
Electrical power		14-20 amps	14-20 amps	20-29 amps
Spiral rotation speed		105/210 rpm	105/210 rpm	105/210 rpm
Spiral thickness		17.71"	17.71"	19.68"
Bowl rotation speed		10/20 rpm	10/20 rpm	10/20 rpm
Bowl left/right rotation		YES	YES	YES
Weight		1873 lb	1906 lb	1984 lb

PROMAC Bakery Equipment
 170 Wilbur Place, Suite 300, Bohemia NY 11716
 Direct Phone & Service: (516) 286-3609
 Website: www.promacbakeryequipment.com
 Mail: info@promacbakeryequipment.com