

Suitable for scaling soft and delicate dough this type of divider does not over-work the dough. In fact the suction cutting system does not press the piece of dough inside the piston but it suck it in and expel it. The machine is provided with a closed lubrication circuit with oil filtering and recovery. The weight adjustment is made through an electrical device with display located on the control panel or manually with the flywheel located in the back of the divider. Stainless steel dough funnel (can be Teflon coated on the inside). Adjustable automatic flour duster. The machine is recommended for use with automatic lines.



Thanks to the double piston and on belt pre-rounder its not only fast but also not space consuming which offers an ideal solution for small shops. Main chassis is made of steel, dividing drum is made of chrome plated steel and the piston chamber is made of stainless steel. Anticorrosive piston, 24V control board, easy motion due to heavy duty casters, closed lubrication system. When machine is stopped it always stops at discharge point. Motor power transfer is done by pulley and belt system. Standard dough funnel has a capacity of 154 lbs. and the large funnel 308 lbs.

Technical specifications of PLC controlled divider:

Weight adjustment is done through the PLC controlled touchscreen. An AC Inverter is standard for speed adjustments between 20 to 40 cuts per minute.

The 2 piston divider is available as 2 models a standard 2 piston with weight ranges from 1.05 oz. up to 10.58 oz. and a industrial model 2 piston divider for the larger weights starting from 2.82 oz. up to 21.16 oz. (see spec table below).



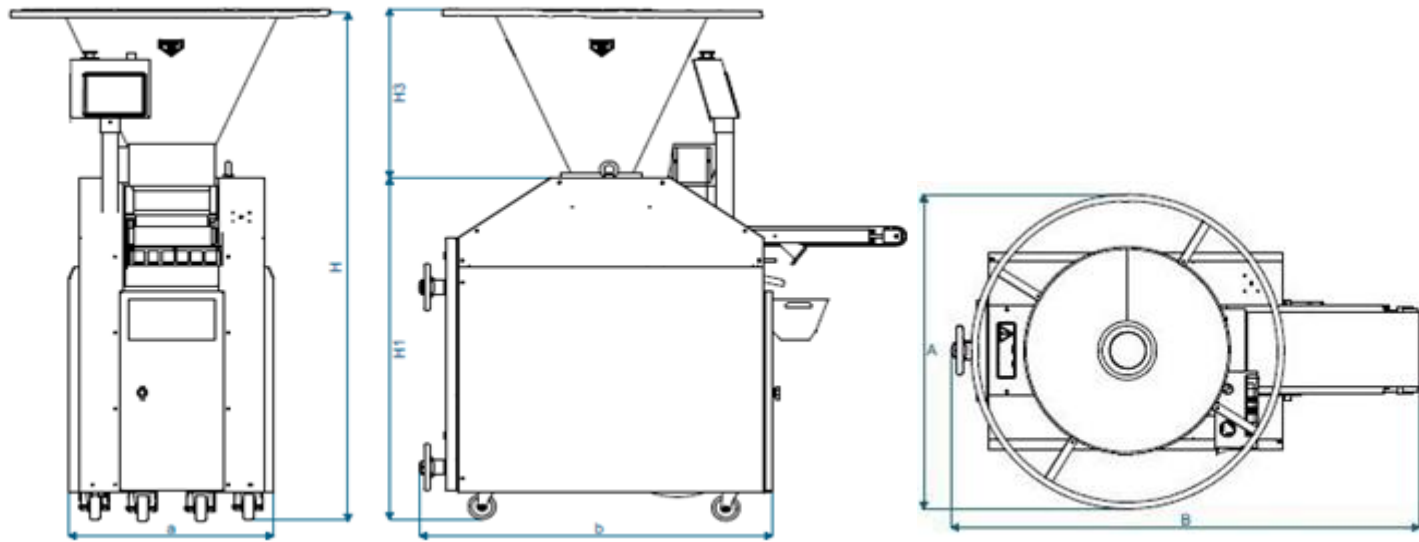

Description		PM-VD M2 STD	PM-VD M2 IND
Control Unit		Electro mechanic	Electro mechanic
Number of pistons		2	2
Capacity		3120-4320	3120-4320
Piston diameter & Weight range		ø50 / 1.05-5.29 oz.	-
		ø60 / 1.41-6.34 oz.	-
		ø70 / 1.76-7.05 oz.	-
		ø80 / 2.11-10.58 oz.	-
		-	ø90 / 2.82-14.10 oz.
		-	ø100 / 3.17-15.87 oz.
		-	ø110 / 3.52-21.16 oz.
Dimensions		A	23.81"
		B	54.33"
		C	63.38"
		D	31.88"-42.15
Funnel capacity		154-308 lb	154-308 lb
Voltage		220V-60Hz + N + PE	
Electrical power		6 amps	6 amps
Weight		1102 lb	1543 lb