

Introducing The PROMAC **ROLL-MATIC-10** DIVIDER/ROUNDER

The New Generation Round Divider With
High Performance For The Industrial Market

Model PM-DR-10

- Touchscreen Siemens Simatic 9''
- PLC Siemens S7 1500
- Drive Siemens - SEW
- Equipped with electric cabinet on board
- Flour duster with separate drive
- Exit belt with separate drive
- Stainless steel and alluminium
- Plastic steel dough hopper
- FDA rules

Optional stocking hopper



Introducing The PROMAC ROLL-MATIC-10 DIVIDER/ROUNDER

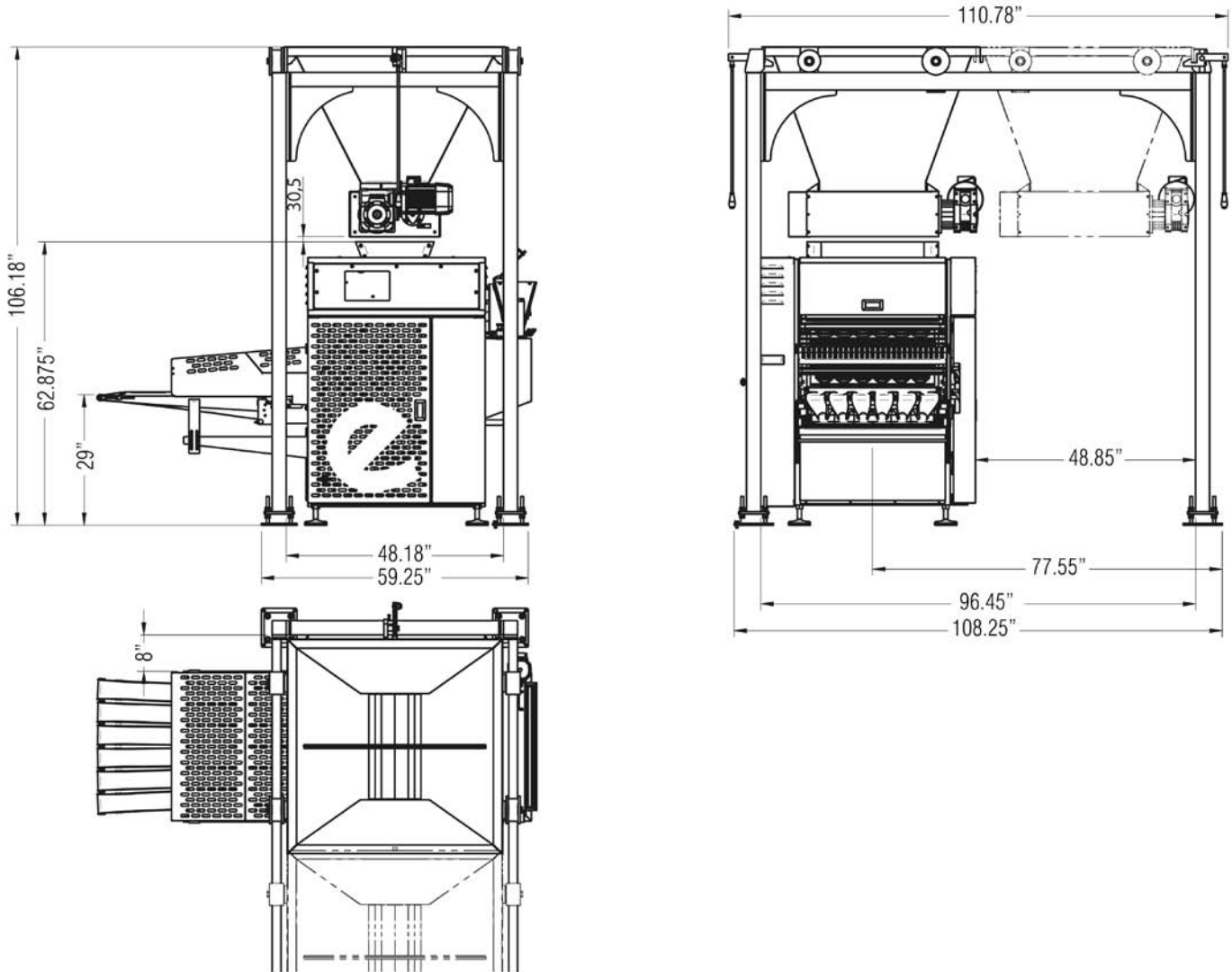

Number Of Rows	3	4	5	6	8	10
Max Weight Dough (Lbs.)	.75	.75	.75	.44	.44	.44
Min Weight Dough (Lbs.)	.06	.06	.06	.06	.06	.06
Stroke Minute	50	50	50	50	50	50
Max Pieces Hour	9000	12000	18000	24000	27000	30000
Theoretically Max Production Lb/Hour	6746	8994	11243	13492	10582	13227