

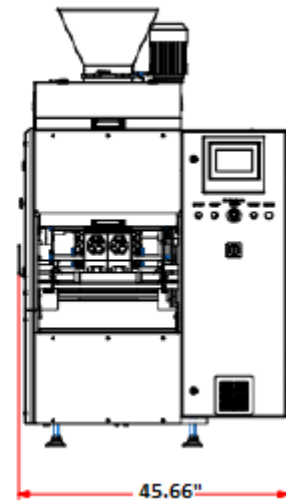

- Easy controls due to multi-functional PLC/HMI screen
- Mechanical adjustments are easy to apply and easy to learn
- Usage information can be stored and recalled at any time
- Daily cleaning made easy
- Parts such as conveyors and other mechanical parts are easily disassembled and re-assembled
- Speed inverters to alter speed on all conveyors
- Electrical and electronic faults that may occur are displayed on the screen together with explanation and image
- Remote access to PLC in case of any software issues (remote problem solving)
- Outer covers and parts that come in contact with dough are chrome or chrome plated
- Available weight ranges:
 - 1.05-4.05 oz.
 - 1.41-4.93 oz.
 - 1.76-5.64 oz.
 - 2.46-7.76 oz.(in order to achieve different weight ranges, different outer drums are available)
- Average capacity: 3600 pcs/h
- Minimum amount of flour is necessary to operate the machine which results in a clean and hygienic working environment.
- Flour dusting on to the cut pieces of dough is adjustable
- Automatic oiling system and different to its competitors no pressure applied on the dough during dividing (stress free).

TECHNICAL SPECIFICATIONS

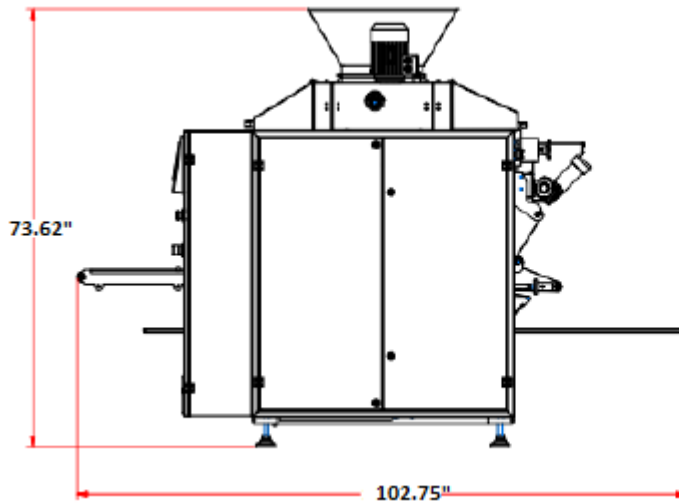

Description		PM-DR 2000
Control unit		Touch screen
Capacity		3600 pcs/h
Width	A	39.17"
Length	B	35.43"
Height	H	52.75"
Voltage		220VAC/60Hz + N
Electrical power		15 amps
Weight		2094 lb

